

Technical Training Course Force – H series

May 2020



C O N T E N T

01 Product Introduction

02 Configuration

03 Installation

04 Power on/off

05 Trouble-shooting

06 Replacement

01

Product Introduction



Technical Specification



| Basic Parameters | FORCE H1 (336V74AH) | FORCE H2 (384V37AH) |
|---|---|---|
| Battery Module | FH48074 | FH9637M |
| Battery Module Voltage(Vdc) | 48 | 96 |
| Battery Module Capacity(Ah) | 74 | 37 |
| Battery Module Qty.(Optional) | 3~7 Pcs | 2~4 Pcs |
| Battery System Capacity(kWh) | 24.86 | 14.21 |
| Battery System Voltage (V) | 336 | 384 |
| Dimension(W*D*H cm) | 600*380*1380 | 450*296*1415 |
| Weight(kg) | 259 | 155 |
| Depth of Discharge | 90% | 90% |
| Charge&Discharge Current (continuous/max., amps) | 37/40 | 18.5/40 |
| Communication | CAN,Modbus | CAN,Modbus |
| Protection Class | IP55 | IP55 |
| Working Temperature(°C) | 0-50 | 0-50 |
| Storage Temperature(°C) | -20-60 | -20-60 |
| Design Life | 15 ⁺ Years(25 °C /77 °F) | 15 ⁺ Years(25 °C /77 °F) |
| Authentication Level | UL/IEC62619/IEC62477/ IEC62040/CE/UN38.3 | UL/IEC62619/IEC62477/ IEC62040/CE/UN38.3 |

- Capacity choice from **7.10 – 24.86kWh**
Force H1 - typical RESS & light commercial
Force H2 - 3-Phase small RESS
- Modular design, flexible on expansion
- **35kG** per module, light on weight
stackable mounting, installation cost save
- **0.5C** continuous running, **40Amps** max.
- Intelligent communication
- Available for **outdoor** installation
- Long life cycle, **10yrs** standard warranty
- Most rigorous safety test

02

Application & Configuration



Application



Back Up



Residential



Commercial

Residential

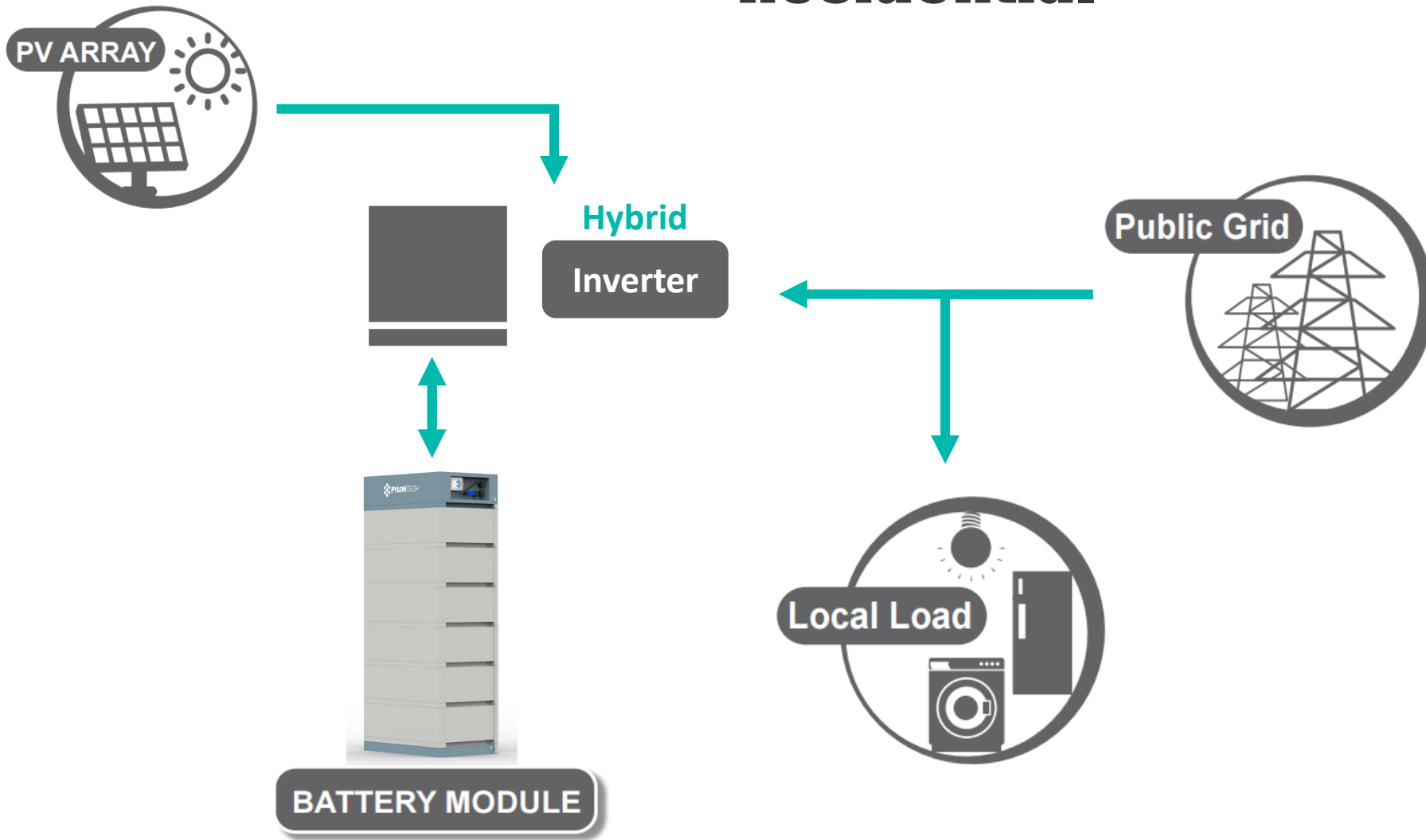

- Back-up
- Peak Shaving
- PV ESS

Reliable and balanced electricity

Configuration

| Item | Amount | Min. Voltage(Vdc) | Max. Voltage(Vdc) | Nominal Capacity(kWh) | Usable Capacity(kWh) | Rated Power(kW)(1) | Peak Power (kW, 15S)(1) | Min. Back-up time(2) |
|------------|--------|-------------------|-------------------|-----------------------|----------------------|--------------------|-------------------------|----------------------|
| Force - H1 | 3 | 130.5 | 162 | 10.7 | 9.6 | 5.3 | 5.8 | 1.8hrs |
| | 4 | 174 | 216 | 14.2 | 12.8 | 7.1 | 7.7 | 1.8hrs |
| | 5 | 217.5 | 270 | 17.8 | 16.0 | 8.9 | 9.6 | 1.8hrs |
| | 6 | 261 | 324 | 21.3 | 19.2 | 10.7 | 11.5 | 1.8hrs |
| | 7 | 304.5 | 378 | 24.9 | 22.4 | 12.4 | 13.4 | 1.8hrs |
| Force - H2 | 2 | 174 | 216 | 7.1 | 6.4 | 3.6 | 7.7 | 1.8hrs |
| | 3 | 261 | 324 | 10.7 | 9.6 | 5.3 | 11.5 | 1.8hrs |
| | 4 | 348 | 432 | 14.2 | 12.8 | 7.1 | 15.4 | 1.8hrs |

(1)Rated/Peak Power is base on ideal operation temperature(10 - 40°C), during charging the power will leveling decrease when reaching full capacity.

(2) Min. Back-up time is base on rated power and related condition during beginning of life, in real application please consider the load.

Quotation Item:

1. Battery Module(FH48074/FH9637M) – varying amount depends on application.
2. BMS(FC0500-40S/FC0500M-40S) – 1pcs per system, include external cables.

03

Installation



Installation Checking List

1) For battery module package:

1*battery module.

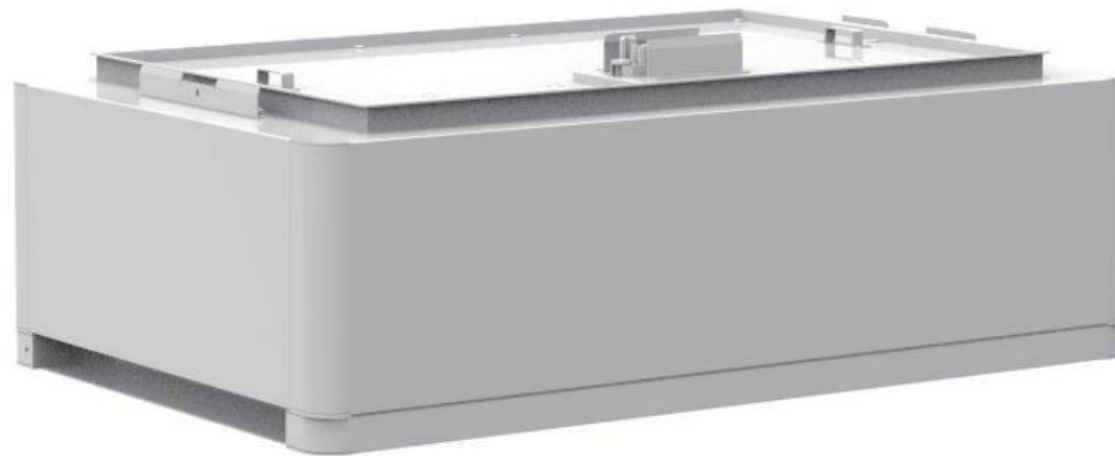

Installation Checking List

2) For BMS package:

1*BMS, 2*long metal bracket, 2*short metal bracket, 1*base, 2*power cable(3.5M),
2*communication cable(3.5M), 1*grounding cable(2M), screws, manual and warranty card.

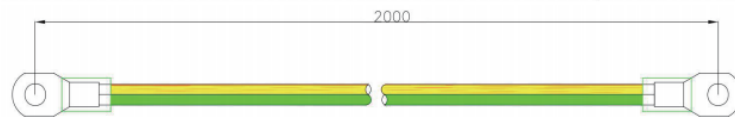
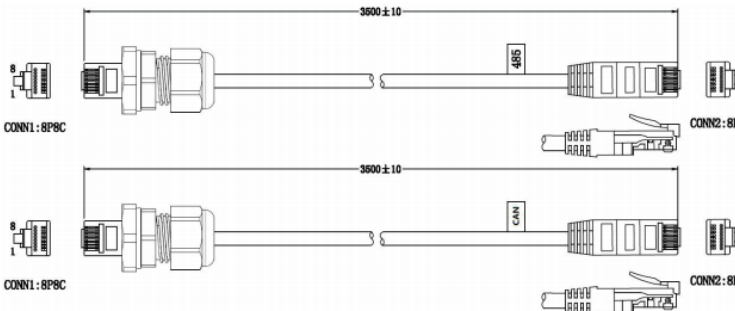
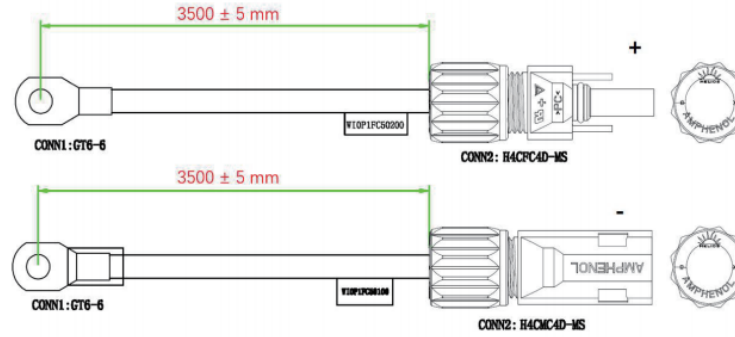
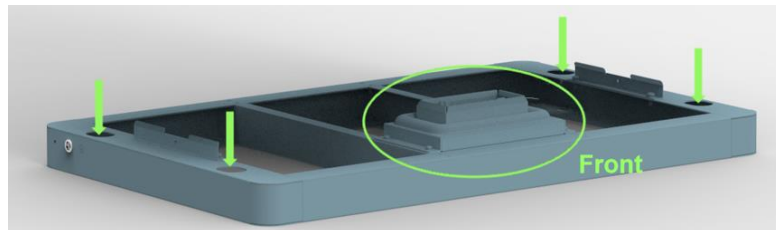

BEFORE YOU START

- Installation Manual
- Location & Environment
- Tools & Accessories
- Compatible Inverter

INSTALLATION

1) Installation of the base:

>300mm above ground, support of 130 ~ 300kG, fixed with 4*M8*80 foundation bolts.

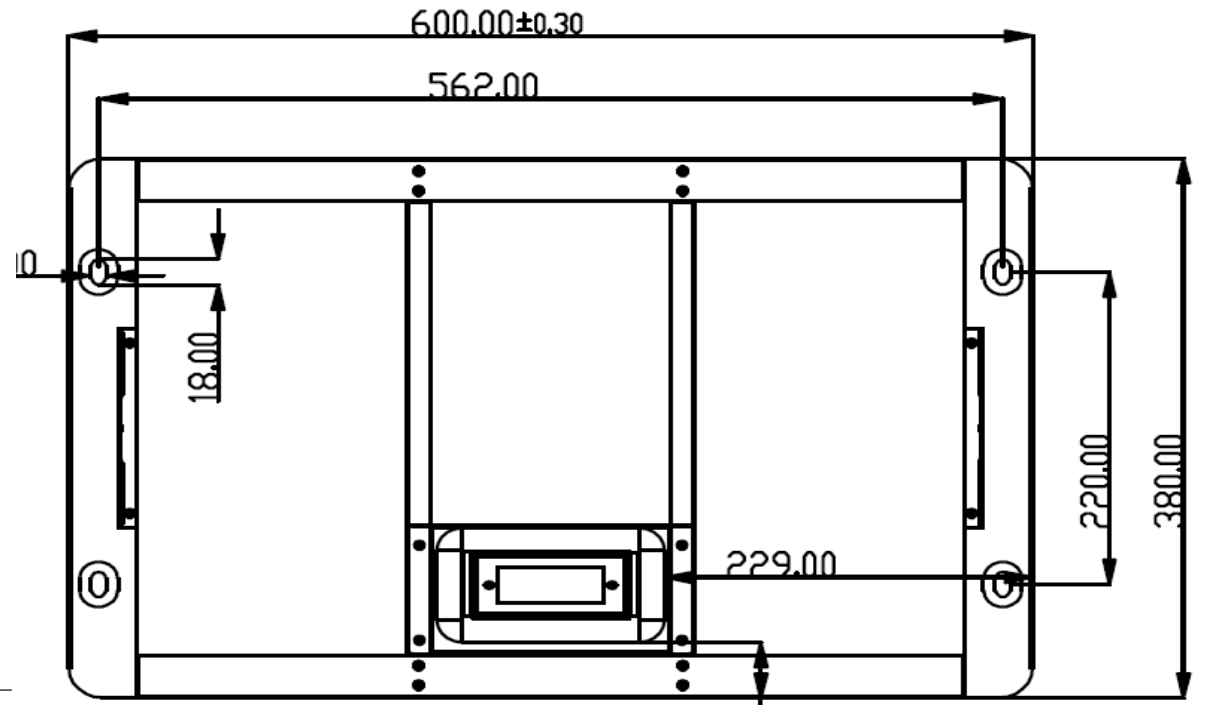
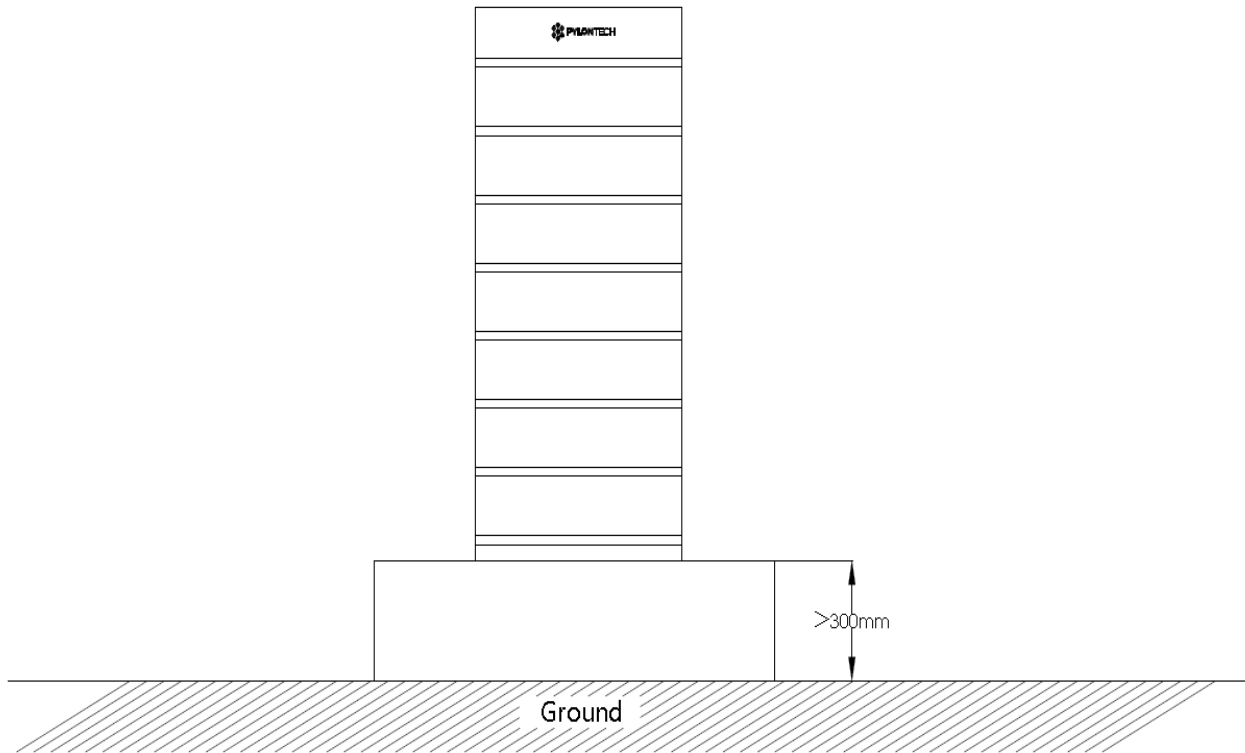

INSTALLATION

2) Mounting battery module and BMS:

Handle the red marked edgings of the both side of these battery modules and control module (BMS).

Do not touch the connector on front.

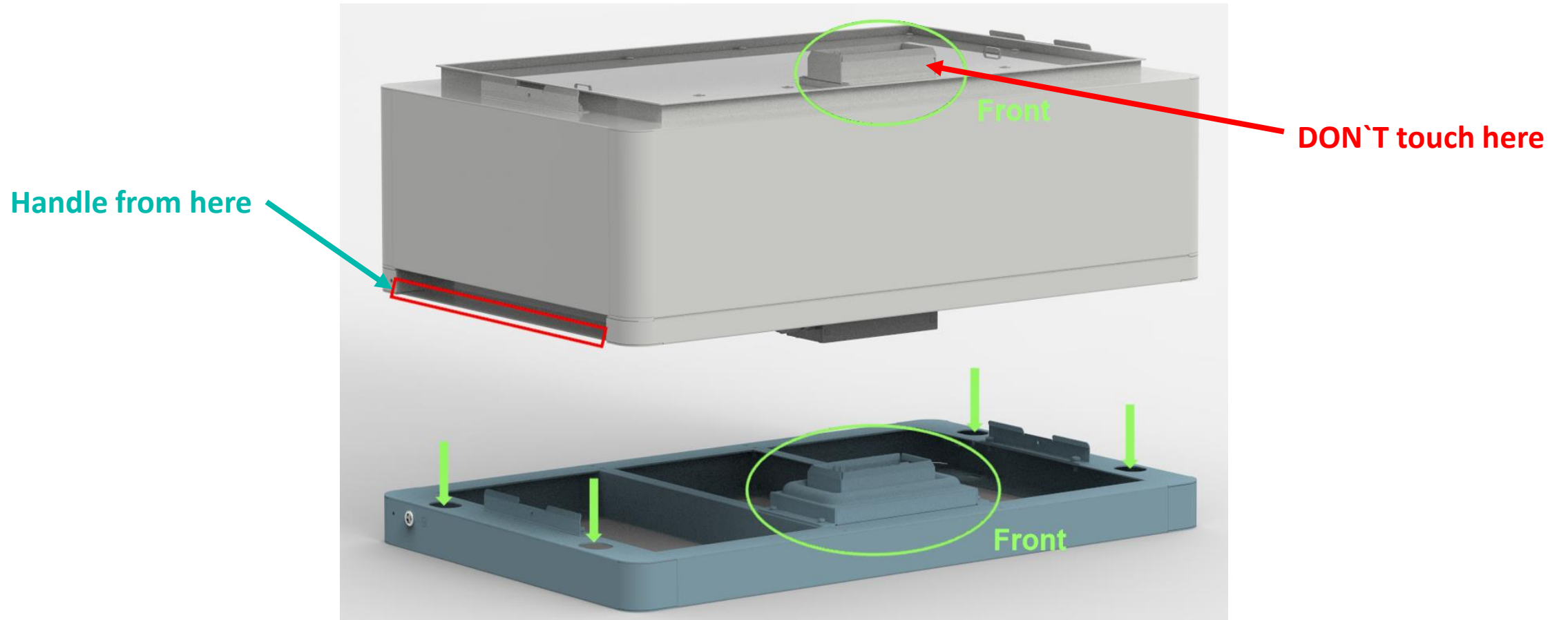

INSTALLATION

3) Fix the metal bracket:

Long bracket – for connecting max. 4 modules; Short bracket – for connecting max. 3 modules.
Bracket can be overlap together; Make sure the bracket is fixed from the base with screws.

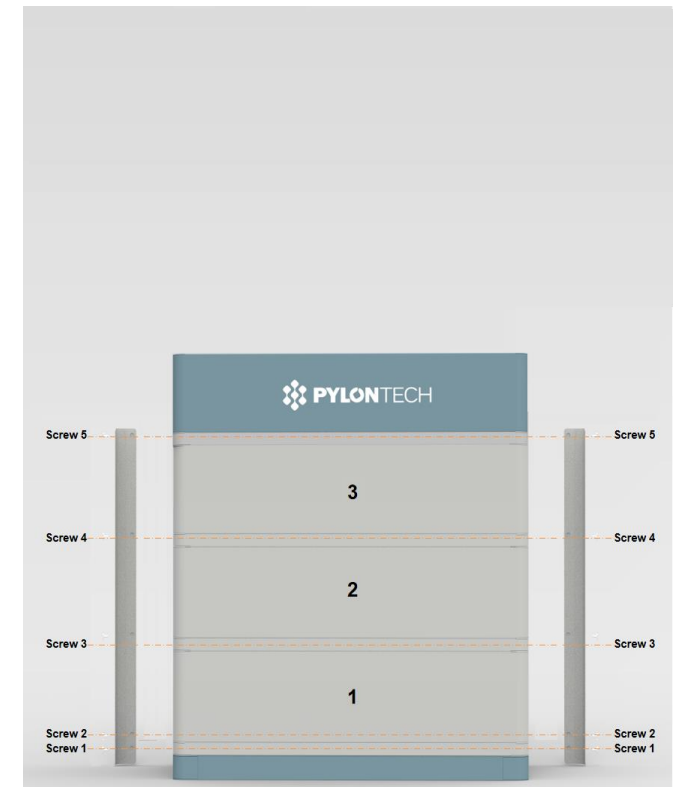
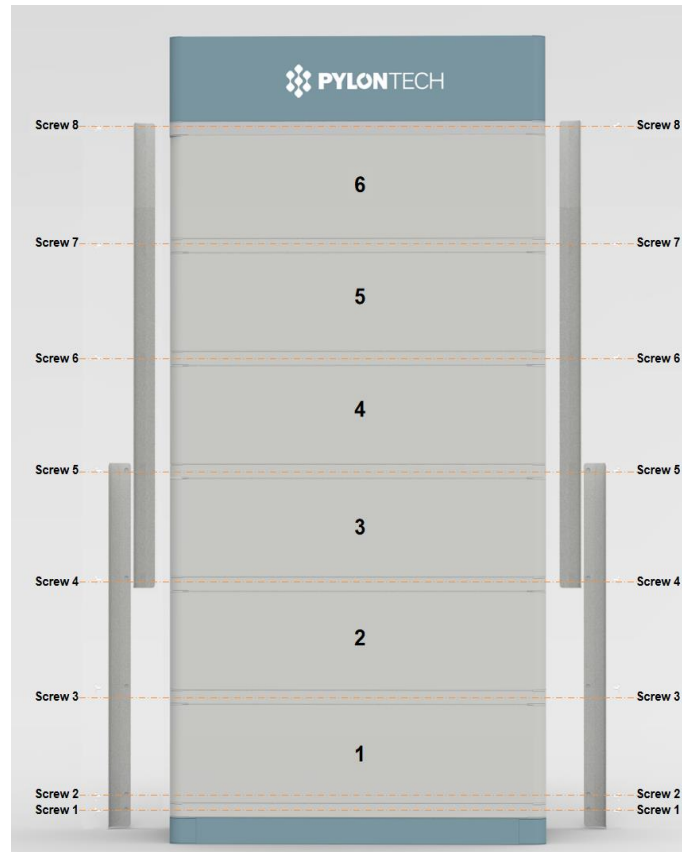

INSTALLATION

4) Lock the BMS with screws:



INSTALLATION

5) Grounding cable connection:

Grounding cable must $\geq 10\text{AWG}$; Resistance must be less than $100\text{m}\Omega$.

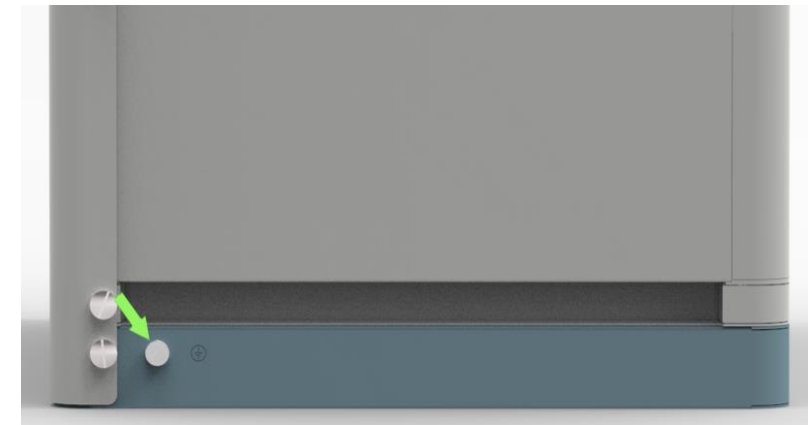
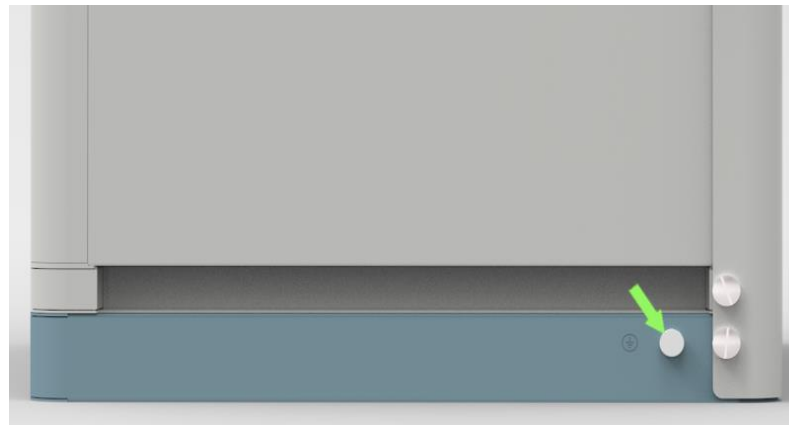
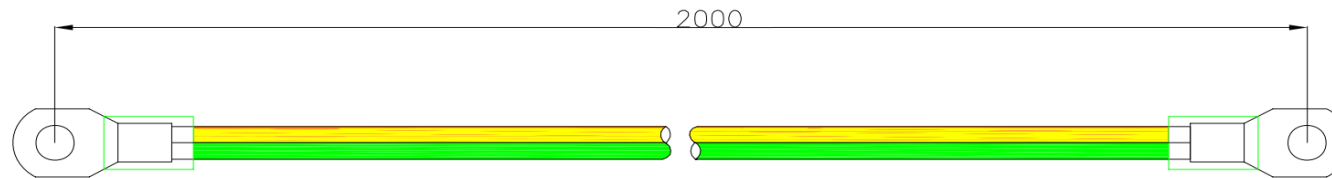

INSTALLATION

6) Connection Panel Interface:

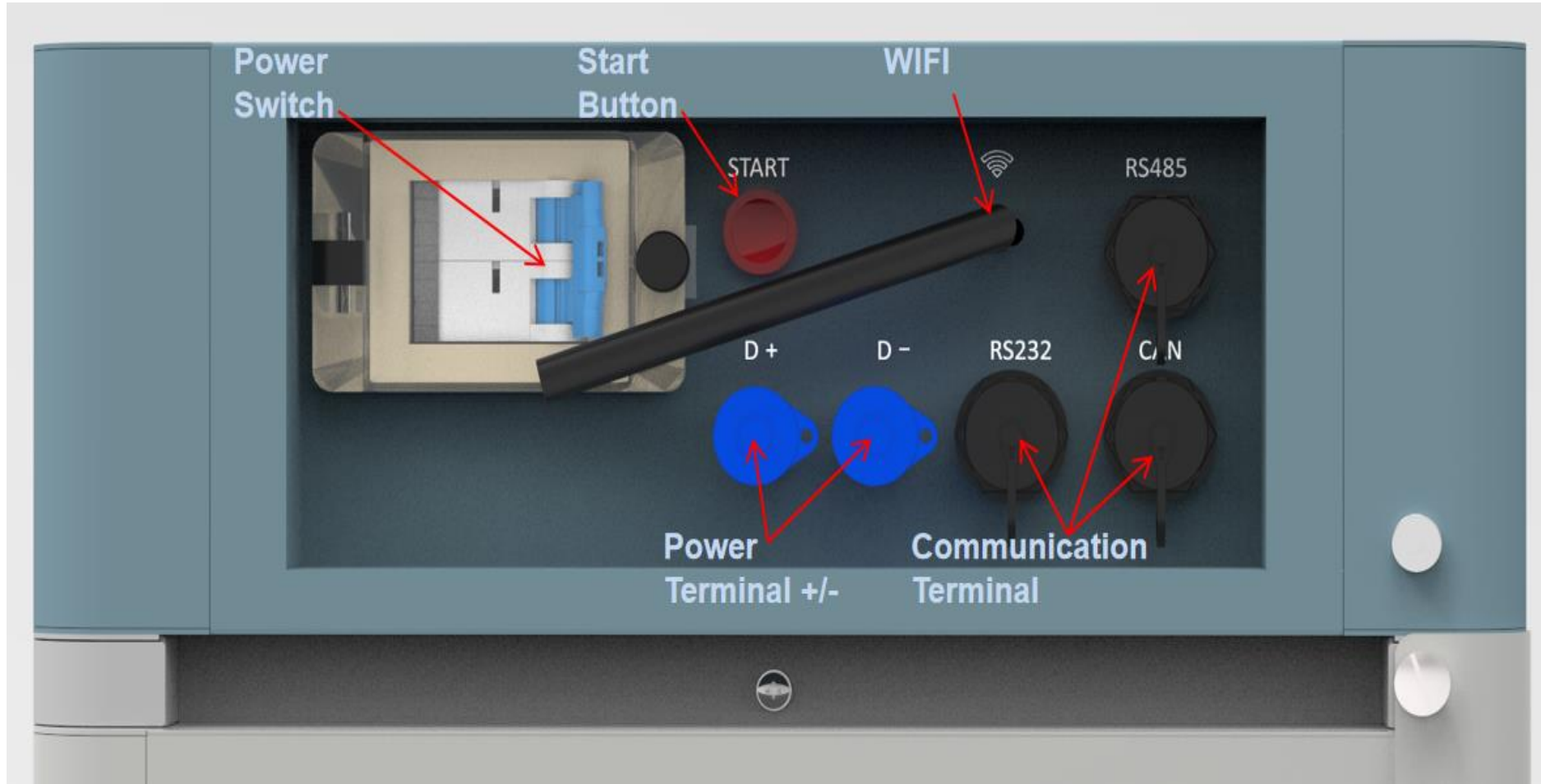

INSTALLATION

7) Communication cable connection:

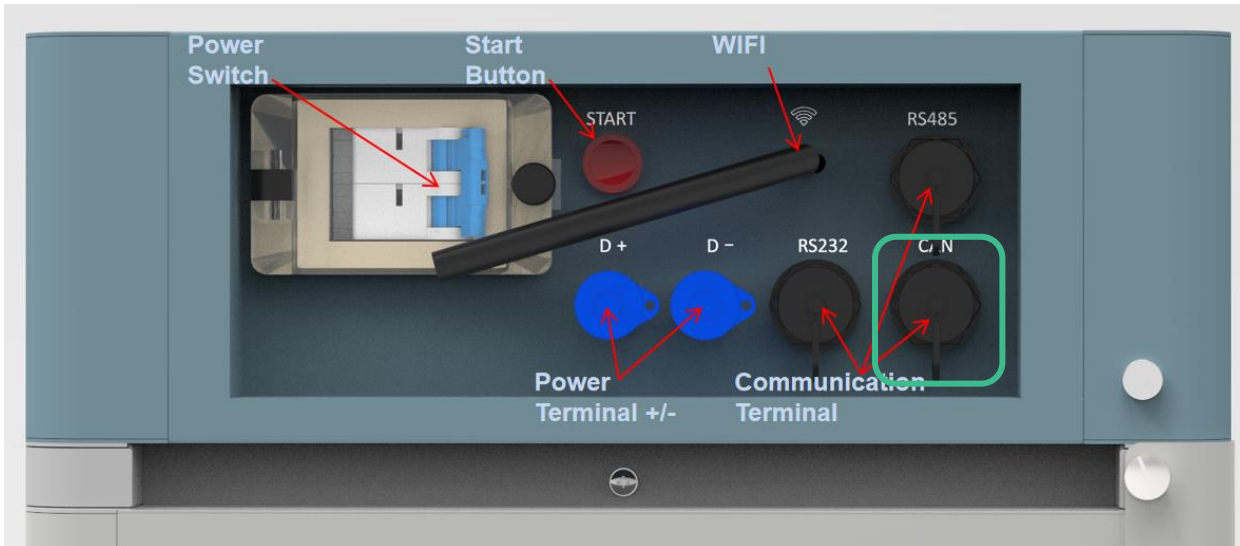
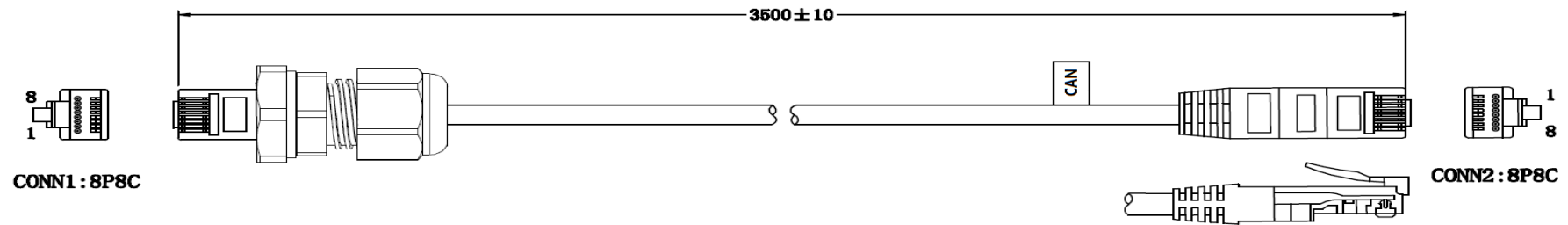

Definition of RJ45 Port Pin

| No. | CAN | RS485 | RS232 |
|-----|------|--------|-------|
| 1 | --- | --- | --- |
| 2 | GND | --- | --- |
| 3 | --- | --- | TX |
| 4 | CANH | --- | --- |
| 5 | CANL | --- | --- |
| 6 | --- | --- | RX |
| 7 | --- | RS485A | --- |
| 8 | --- | RS485B | --- |

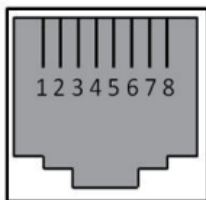

RJ45 Port



RJ45 Plug

INSTALLATION

8) Power cable connection:

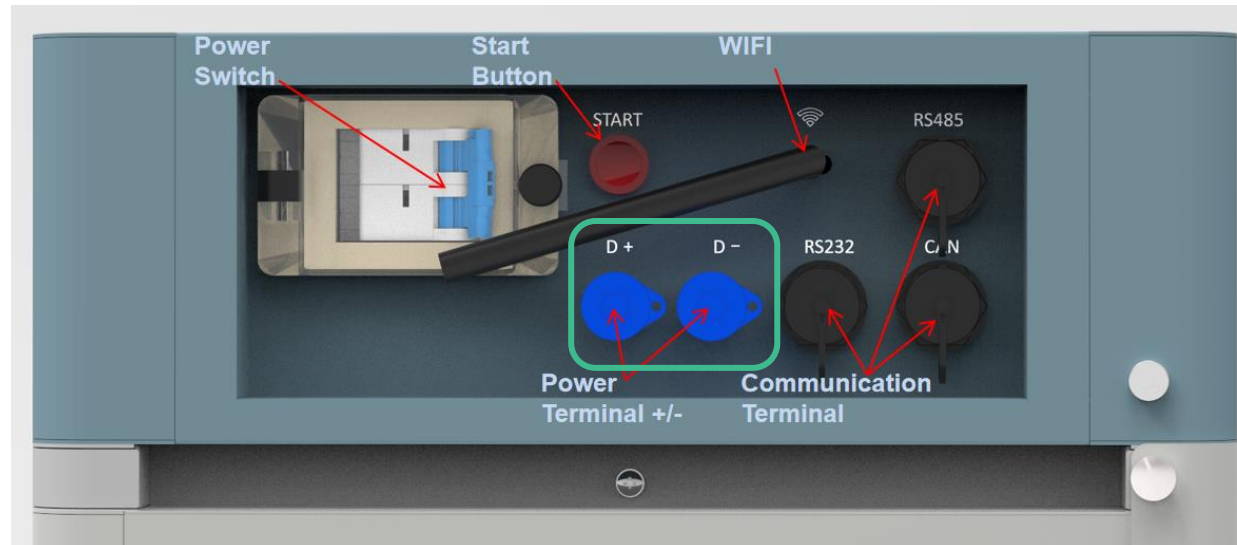
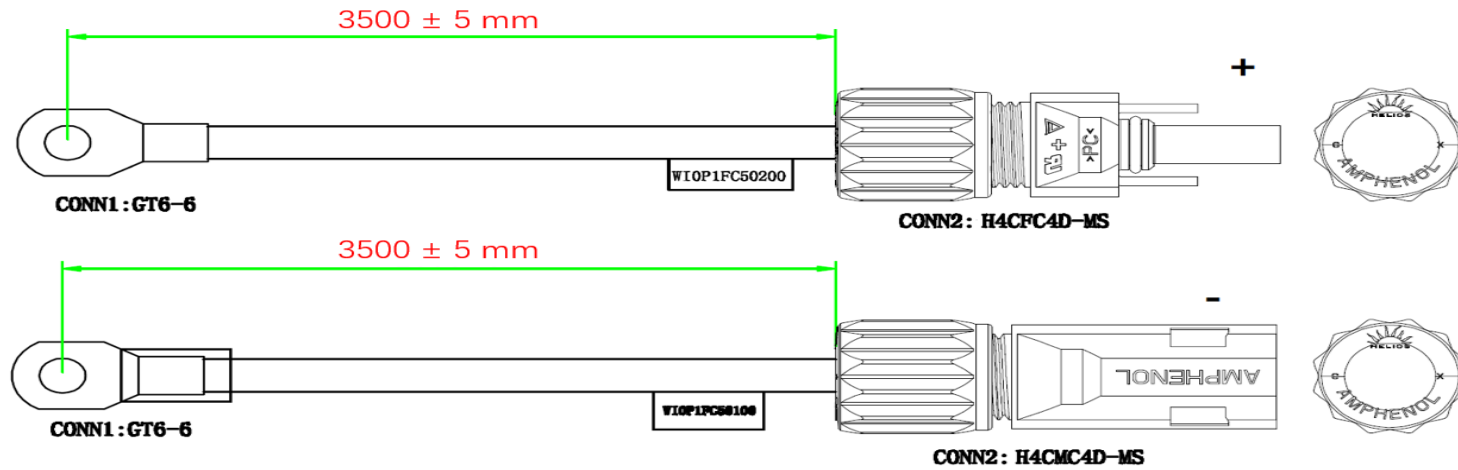



04

Power on/off

Display Panel

1) Display panel:

| LED Button | | |
|---|-----------------------------------|---|
|  | Short Press | Display the LED panel for 20sec. |
| | Long Press (more than 5sec) | When status LED fast flashes blue ●, loss the button, then it is 115200 baud rate of RS485. |
| | | When status LED fast flashes orange ●, loss the button, then it is 9600 baud rate of RS485. |

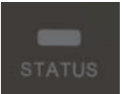
| Status | |
|---|---|
|  | 2 colors, Blue and orange Refer to [LED Indicators Instructions] |

| Battery Module Status | | |
|--|--------------|--|
|  | Blue solid | Normal |
| | Orange solid | Individual module alarm or protection. See trouble shooting steps in section 5.1 |

| System Capacity | |
|---|--|
|  | System SOC Each LED indicate 25%SOC |

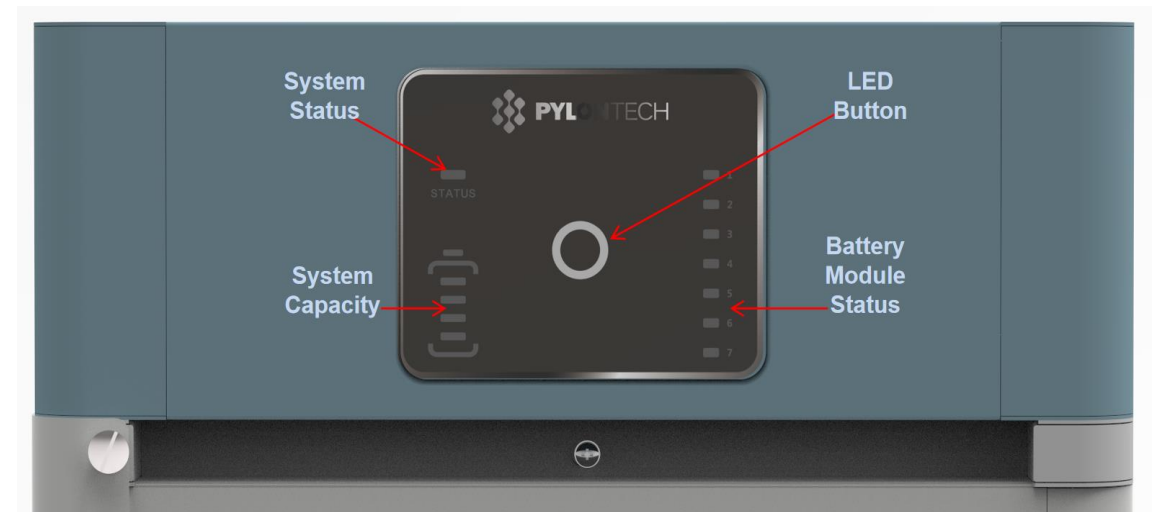

Indicate the system SOC.



Display Panel

1) Display panel:

LED Indicators Instructions

| Condition |  |  | Note |
|---------------------------------|---|---|--|
| Self-checking | Blue, Flashing | All flashing | |
| Self-checking failure | Orange, Slow flashing | Off | Battery Module Status off. See trouble shooting steps in section 5.1 |
| Black start success | Blue, fast flashing | Off | |
| Black start failure | Orange, Fast flashing | Off | See trouble shooting steps in section 5.1 |
| Communication Lost or BMS error | Orange, solid | Indicate SOC, blue, solid | See trouble shooting steps in section 5.1 |
| Idle | Blue, slow flashing | Indicate SOC, blue, solid | |
| Charge | Blue, solid | Indicate SOC, blue, solid | |
| Floating charge | Blue, solid | All flashing, horse race lamp | |
| Discharge | Blue, flashing | Indicate SOC, blue, solid | |
| System sleep | Blue, flashing | Off | Battery module status off |

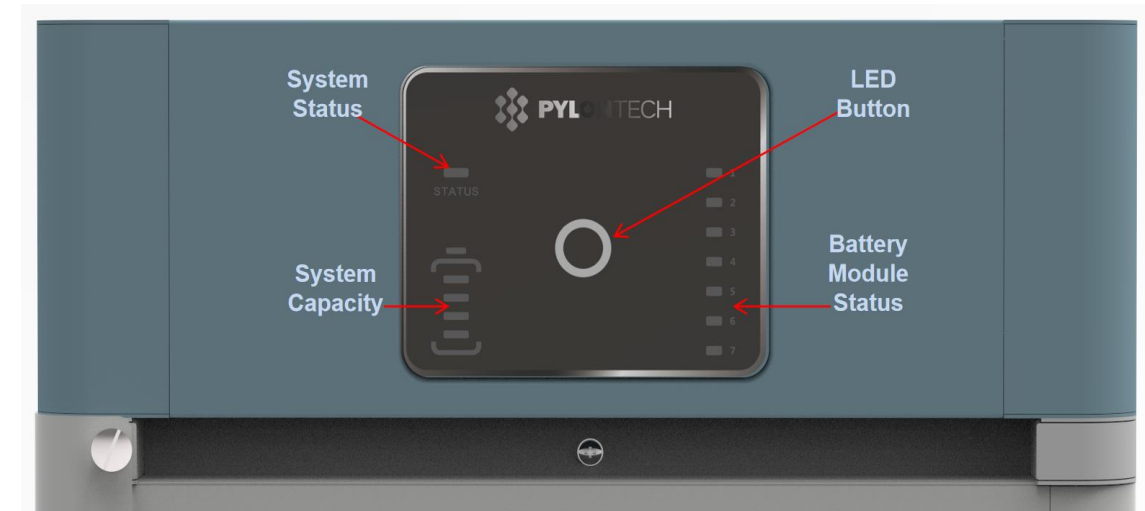

POWER ON

2) Power on:

Double check all the previous installation procedures.

1. Switch ON Power Switch.
2. Press Start Button for $\geq 5S$, or till buzzer rings.
3. BMS need $\sim 30S$ for self-checking.

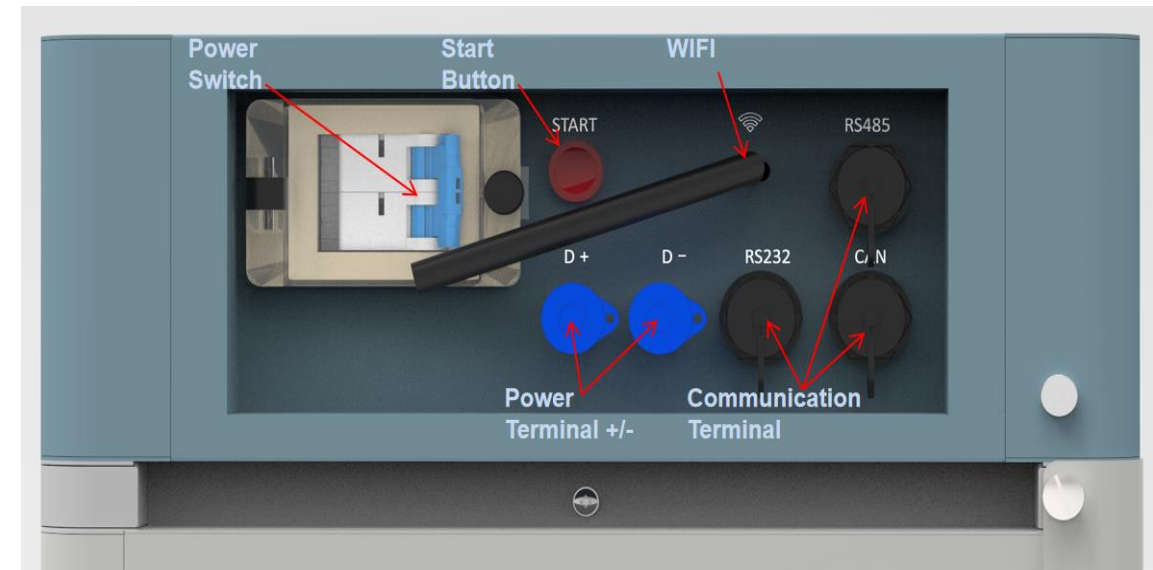

*Make sure there is communication between inverter and BMS, otherwise will report external communication lost and no power output.

*When the breaker is tripped off because of over current or short circuit, must wait after 10min to turn on it again, otherwise may cause the breaker damage.

*During first time power on, the system will require to do fully charge progress for SOC calibration purpose.

*It's also suggest to follow the BMS full charge flag to fully charged the system every 90days for better performance.

POWER ON

3) Black start:

Double check all the previous installation procedures.

1. Switch ON Power Switch.
2. Press Start Button for $\geq 5S$, or till buzzer rings.
3. BMS need $\sim 30S$ for self-checking.

Status: Orange, solid

SOC: blue, solid

4. Press the Start button again for $\geq 10S$, till the **Status** lighting

Blue and fast flashing, then battery will black start to support inverter for 10mins to establish communication.

*Make sure there is communication between inverter and BMS, otherwise will report external communication lost and no power output.

*When the breaker is tripped off because of over current or short circuit, must wait after 10min to turn on it again, otherwise may cause the breaker damage.

*During first time power on, the system will require to do fully charge progress for SOC calibration purpose.

*It's also suggest to follow the BMS full charge flag to fully charged the system every 90days for better performance.

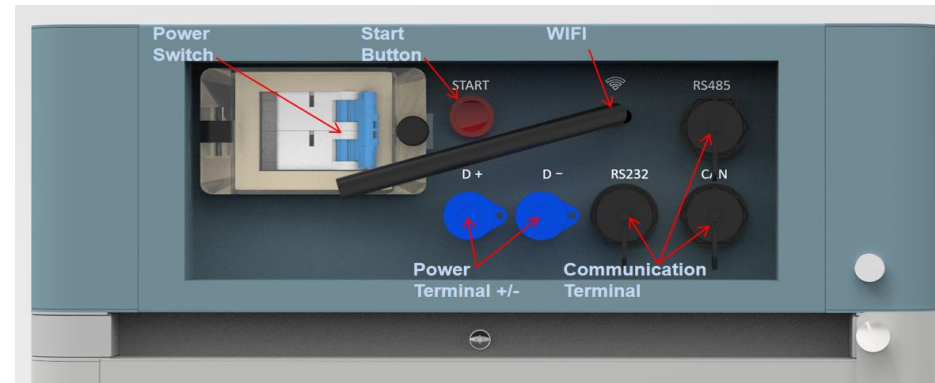
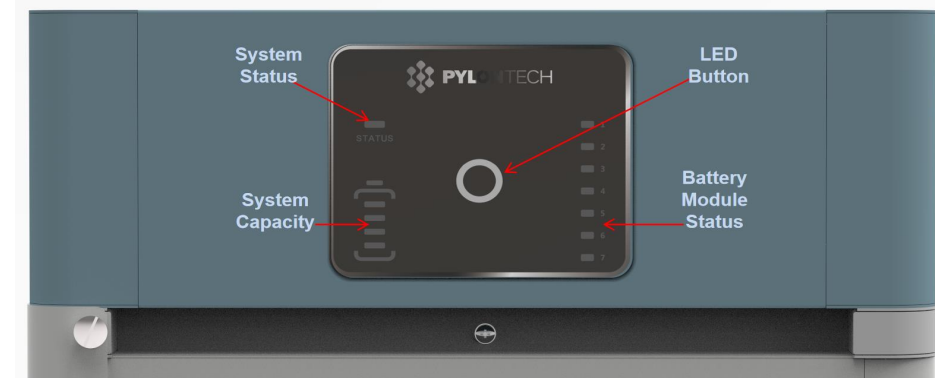

POWER OFF

4) Power off:

Double check all the previous installation procedures.

1. Turn off inverter or power supply on DC side.
2. Turn off the switch between PCS and battery system.
3. Turn off the “Power Switch” of the BMS.

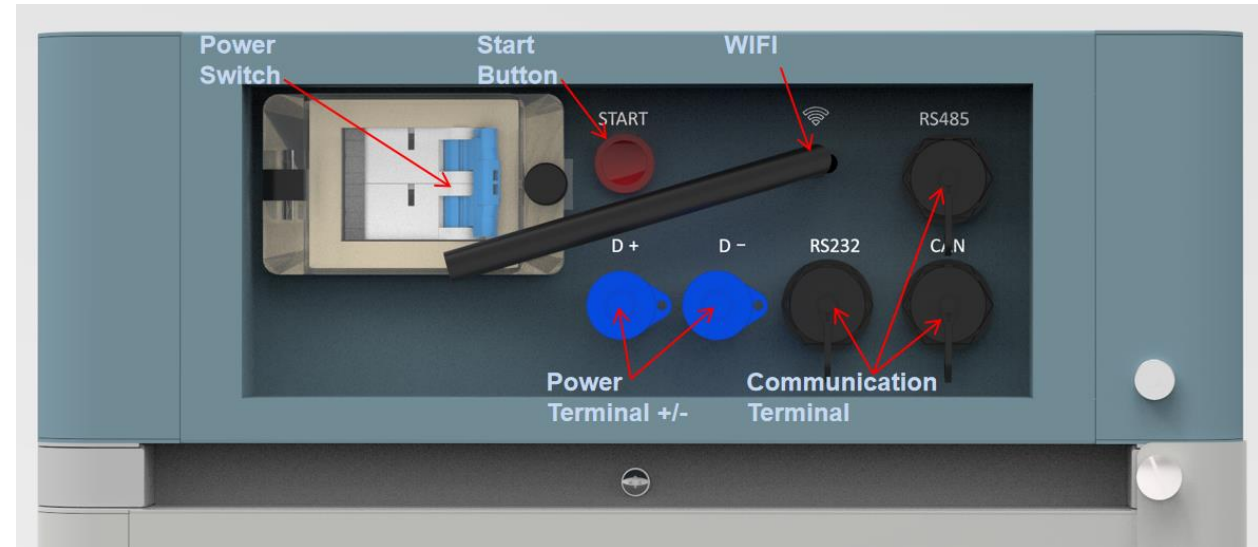

05

Trouble shooting





Check List

- Environment
- Power cable connection
- Communication pinout & baud-rate
- Display panel
- Trouble shooting table
- Maintenance tool / Upper controller

Trouble shooting

- Display panel

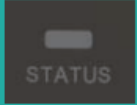
LED Indicators Instructions

| Condition |  |  | Note |
|---------------------------------|---|---|--|
| Self-checking | Blue, Flashing | All flashing | |
| Self-checking failure | Orange, flashing Slow | Off | Battery Module Status off. See trouble shooting steps in section 5.1 |
| Black start success | Blue, fast flashing | Off | |
| Black start failure | Orange, flashing Fast | Off | See trouble shooting steps in section 5.1 |
| Communication Lost or BMS error | Orange, solid | Indicate SOC, blue, solid | See trouble shooting steps in section 5.1 |
| Idle | Blue, slow flashing | Indicate SOC, blue, solid | |
| Charge | Blue, solid | Indicate SOC, blue, solid | |
| Floating charge | Blue, solid | All flashing, horse race lamp | |
| Discharge | Blue, flashing | Indicate SOC, blue, solid | |
| System sleep | Blue, flashing | Off | Battery module status off |

Trouble shooting

● Trouble shooting table

Check the environment first

| No | Problem | Possible Reason | Solution |
|----|---|---|--|
| 1 | No power output, no led on. | Press start button too short. | To turn on, at least 5s To black start, at least 10s. |
| | | The button battery in controller is missing or failure. The power supply in controller is failure | Change the controller module. |
| | | The battery voltage is too low. | Make sure at least 3 battery modules. |
| | | The connector of base is failure | The base is not connected or change the base |
| 2 | After turned on, status LED slow flashing orange. Others off. | Self-checking failure. DC side has a voltage, but voltage difference with the battery system is higher than 20V. | Make sure no DC voltage or set correct DC voltage before press start button. Then follow turn on process. |
| | | BMS internal failure. | Use debug tool to further analysis or change the controller module. |
| 3 | Status LED fast flashing orange, others off. | The time interval after last time black start is too short. | Wait more than 5 minutes and try black start again. |
| | | The battery system under error condition such as: temperature or current protection or other error, thus do not response black start. | Make sure no other protection factor. Or use debug tool to further analysis. |
| 4 | Buzzer rings continue | Relay adhesion or failure. | Completely disconnect battery system with any DC source then make a restart. If problem remain, then swap the controller. |
| 5 | Status LED solid orange. Battery module LED blue solid. | Communication lost with inverter | Check the communication cable PIN and wiring whether is correctly. |

| | | | |
|---|--|---|--|
| | | Over current protection. | Check DC side. And wait until BMS release protection. |
| | | Controller failure. | Use debug tool to further analysis or change the controller module. Or use debug tool. |
| 6 | Status LED solid orange. Battery module exists LED in orange solid | Over/ under temperature protection. | Check environment temperature. And wait BMS release. |
| | | Over voltage protection. | Check DC charge voltage setting or wait BMS release. |
| | | Under voltage protection. | Use black start function, and then charge the system. |
| | | Battery module BMS failure | Use debug tool to further analysis or change the battery module. |
| 7 | All LED blue but no output. | Fuse fusing | Change the controller module |
| 8 | Other failure | Cell failure or electrical board failure. Or failure need debug tool for further debug. | Can't find out failure point or can't check. Please contact with distributor or Pylontech. |

Once a certain failure detected following the trouble shooting steps, shut down the battery string first before replacement to avoid further over discharge to the system due to the self-consumption.

Maintenance tool / Upper controller

● Battery View

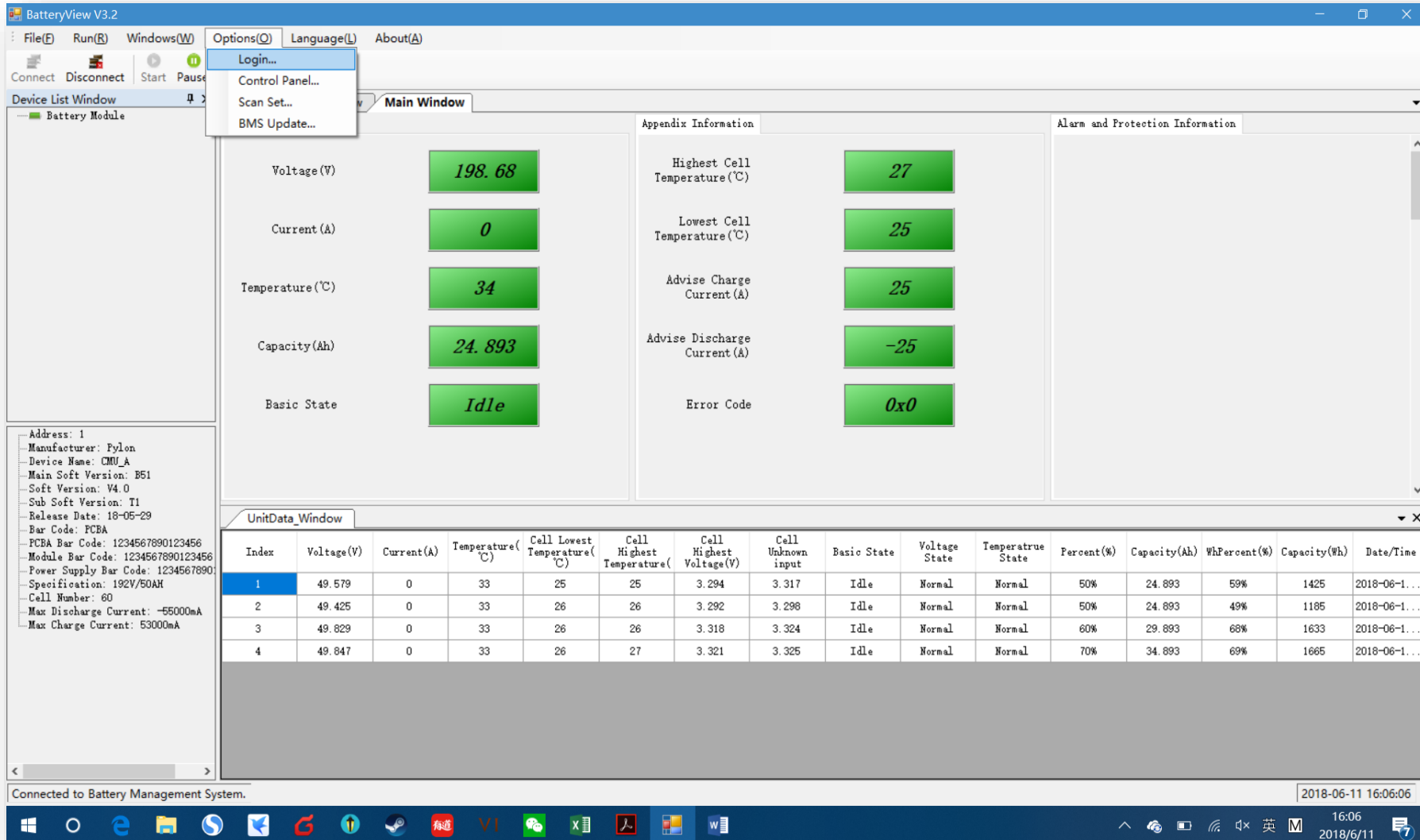

The screenshot shows the BatteryView V3.2 software interface. The main window displays several key metrics in green boxes:

- Voltage (V): 198.68
- Current (A): 0
- Temperature (°C): 34
- Capacity (Ah): 24.893
- Basic State: Idle

Appendix Information includes:

- Highest Cell Temperature (°C): 27
- Lowest Cell Temperature (°C): 25
- Advise Charge Current (A): 25
- Advise Discharge Current (A): -25
- Error Code: 0x0

Alarm and Protection Information is currently empty.

The UnitData_Window at the bottom shows a table of battery cell data:

| Index | Voltage(V) | Current(A) | Temperature(°C) | Cell Lowest Temperature(°C) | Cell Highest Temperature(°C) | Cell Highest Voltage(V) | Cell Unknown input | Basic State | Voltage State | Temperature State | Percent(%) | Capacity(Ah) | WhPercent(%) | Capacity(Wh) | Date/Time |
|-------|------------|------------|-----------------|-----------------------------|------------------------------|-------------------------|--------------------|-------------|---------------|-------------------|------------|--------------|--------------|--------------|--------------|
| 1 | 49.579 | 0 | 33 | 25 | 25 | 3.294 | 3.317 | Idle | Normal | Normal | 50% | 24.893 | 59% | 1425 | 2018-06-1... |
| 2 | 49.425 | 0 | 33 | 26 | 26 | 3.292 | 3.298 | Idle | Normal | Normal | 50% | 24.893 | 49% | 1185 | 2018-06-1... |
| 3 | 49.829 | 0 | 33 | 26 | 26 | 3.318 | 3.324 | Idle | Normal | Normal | 60% | 29.893 | 68% | 1633 | 2018-06-1... |
| 4 | 49.847 | 0 | 33 | 26 | 27 | 3.321 | 3.325 | Idle | Normal | Normal | 70% | 34.893 | 69% | 1665 | 2018-06-1... |

Device List Window shows a Battery Module connected. The bottom status bar indicates "Connected to Battery Management System." and the system tray shows the date and time as 2018-06-11 16:06:06.

Connecting through BMS

RS232 Port to Laptop

- Monitoring
- Firmware Upgrade
- Acquire Historical Log
- Setting Change
- [Error Code](#)

Firmware Upgrade

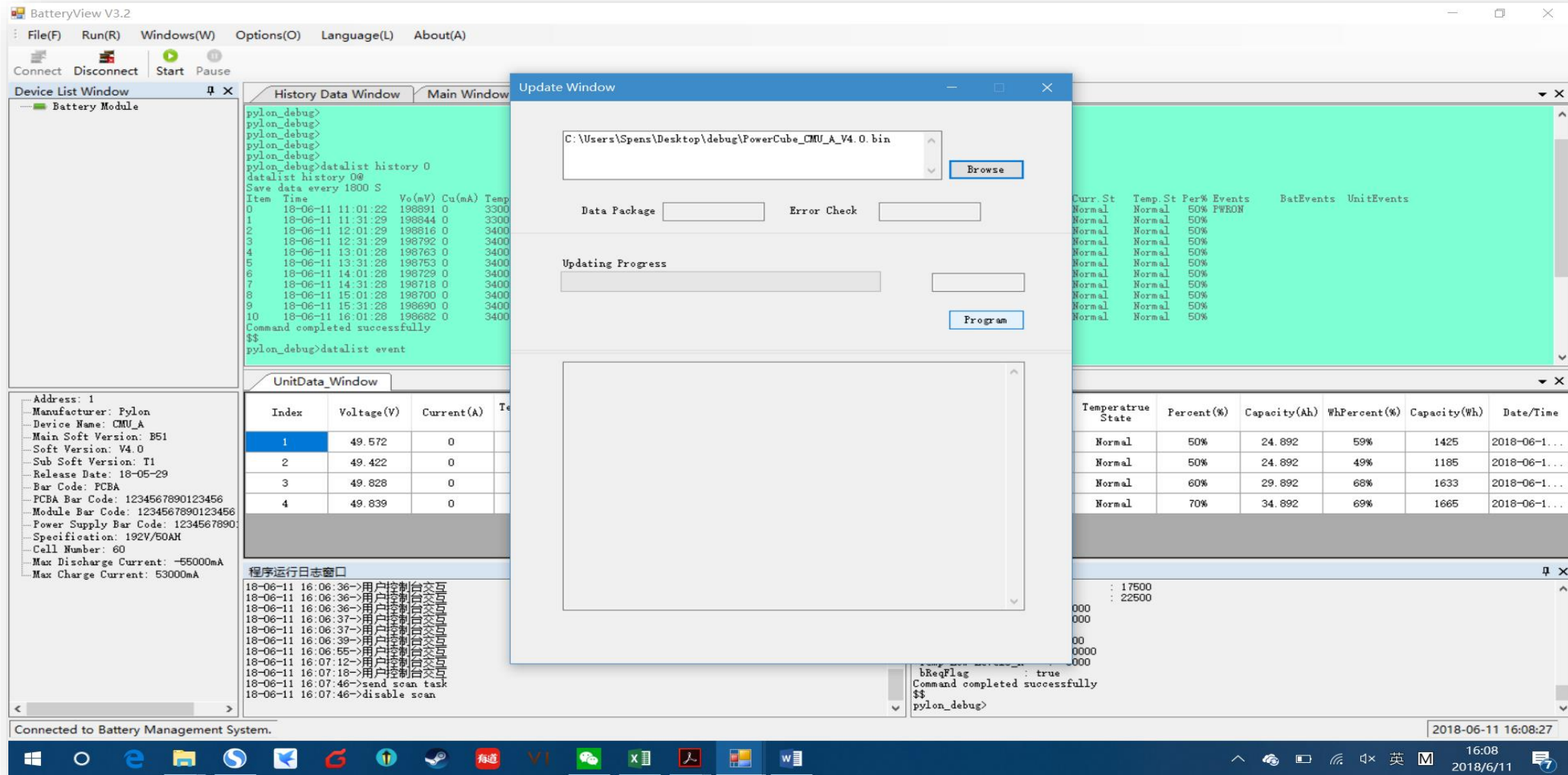

Device List Window

- Address: 1
- Manufacturer: Pylon
- Device Name: CMU_A
- Main Soft Version: B51
- Soft Version: V4.0
- Sub Soft Version: T1
- Release Date: 18-05-29
- Bar Code: PCBA
- PCBA Bar Code: 1234567890123456
- Module Bar Code: 1234567890123456
- Power Supply Bar Code: 12345678901
- Specification: 192V/50AH
- Cell Number: 60
- Max Discharge Current: -55000mA
- Max Charge Current: 53000mA

History Data Window

```
pylon_debug>
pylon_debug>
pylon_debug>
pylon_debug>
pylon_debug>datalist history 0
datalist history 0@
Save data every 1800 S
Item  Time      Vo(mV)  Cu(mA)  Temp
0   18-06-11 11:01:22 198891 0    3300
1   18-06-11 11:31:29 198844 0    3300
2   18-06-11 12:01:29 198816 0    3400
3   18-06-11 12:31:29 198792 0    3400
4   18-06-11 13:01:28 198763 0    3400
5   18-06-11 13:31:28 198753 0    3400
6   18-06-11 14:01:28 198729 0    3400
7   18-06-11 14:31:28 198718 0    3400
8   18-06-11 15:01:28 198700 0    3400
9   18-06-11 15:31:28 198690 0    3400
10  18-06-11 16:01:28 198682 0    3400
Command completed successfully
$$
pylon_debug>datalist event
```

UnitData_Window

| Index | Voltage(V) | Current(A) | Temp |
|-------|------------|------------|------|
| 1 | 49.572 | 0 | |
| 2 | 49.422 | 0 | |
| 3 | 49.828 | 0 | |
| 4 | 49.839 | 0 | |

Update Window

C:\Users\Spens\Desktop\debug\PowerCube_CMU_A_V4.0. bin

Data Package Error Check

Updating Progress

Program

Main Window

```
bReqFlag : true
Command completed successfully
$$
pylon_debug>
```

Device List Window

| Temperatru State | Percent(%) | Capacity(Ah) | WhPercent(%) | Capacity(Wh) | Date/Time |
|------------------|------------|--------------|--------------|--------------|--------------|
| Normal | 50% | 24.892 | 59% | 1425 | 2018-06-1... |
| Normal | 50% | 24.892 | 49% | 1185 | 2018-06-1... |
| Normal | 60% | 29.892 | 68% | 1633 | 2018-06-1... |
| Normal | 70% | 34.892 | 69% | 1665 | 2018-06-1... |

程序运行日志窗口

```
18-06-11 16:06:36->用户控制文本与电池控制文本
18-06-11 16:06:36->用户控制文本与电池控制文本
18-06-11 16:06:36->用户控制文本与电池控制文本
18-06-11 16:06:37->用户控制文本与电池控制文本
18-06-11 16:06:37->用户控制文本与电池控制文本
18-06-11 16:06:39->用户控制文本与电池控制文本
18-06-11 16:06:55->用户控制文本与电池控制文本
18-06-11 16:07:12->用户控制文本与电池控制文本
18-06-11 16:07:18->用户控制文本与电池控制文本
18-06-11 16:07:46->send soan task
18-06-11 16:07:46->disable soan
```

Connect to Battery View → Option → BMS Update → Browse firmware → Program till 100%

Sample Log File

| No. | TIME | VOLTAGE (V) | CURRENT (A) | TEMP (°C) | Single cell Lowest Temp (°C) | Single cell Highest Temp (°C) | Single cell Lowest voltage (V) | Single cell Highest voltage (V) | Basic Status | Voltage Status | Current Status | Temp. Status | SOC (%) |
|-----|-----------------|-------------|-------------|-----------|---------------------------------|----------------------------------|-----------------------------------|------------------------------------|-----------------|-------------------|-------------------|-----------------|---------|
| 0 | 2017/7/17 17:20 | 49.294 | -0.05 | 19 | 16 | 17 | 3.284 | 3.287 | Dischg | Normal | Normal | Normal | 58.00% |
| 1 | 2017/7/17 17:50 | 49.282 | 0 | 19 | 16 | 17 | 3.284 | 3.287 | Idle | Normal | Normal | Normal | 58.00% |
| 2 | 2017/7/17 18:20 | 49.28 | -0.05 | 19 | 16 | 16 | 3.284 | 3.287 | Dischg | Normal | Normal | Normal | 58.00% |
| 3 | 2017/7/17 18:50 | 49.28 | 0 | 19 | 16 | 16 | 3.284 | 3.287 | Idle | Normal | Normal | Normal | 58.00% |
| 4 | 2017/7/17 19:20 | 49.282 | -0.025 | 19 | 16 | 16 | 3.284 | 3.287 | Dischg | Normal | Normal | Normal | 58.00% |
| 5 | 2017/7/17 19:50 | 49.277 | -0.05 | 19 | 16 | 16 | 3.284 | 3.286 | Dischg | Normal | Normal | Normal | 58.00% |
| 6 | 2017/7/17 20:20 | 49.277 | -0.05 | 19 | 15 | 16 | 3.284 | 3.286 | Dischg | Normal | Normal | Normal | 57.00% |
| 7 | 2017/7/17 20:50 | 49.271 | 0 | 19 | 15 | 16 | 3.283 | 3.286 | Idle | Normal | Normal | Normal | 57.00% |
| 8 | 2017/7/17 21:20 | 49.268 | 0 | 19 | 15 | 16 | 3.284 | 3.286 | Idle | Normal | Normal | Normal | 57.00% |
| 9 | 2017/7/17 21:50 | 49.268 | 0 | 18 | 15 | 16 | 3.284 | 3.286 | Idle | Normal | Normal | Normal | 57.00% |
| 10 | 2017/7/17 22:20 | 49.265 | -0.05 | 18 | 15 | 15 | 3.283 | 3.285 | Dischg | Normal | Normal | Normal | 57.00% |
| 11 | 2017/7/17 22:50 | 49.263 | 0 | 19 | 15 | 15 | 3.283 | 3.285 | Idle | Normal | Normal | Normal | 57.00% |
| 12 | 2017/7/17 23:20 | 49.264 | -0.05 | 21 | 15 | 16 | 3.283 | 3.286 | Dischg | Normal | Normal | Normal | 57.00% |
| 13 | 2017/7/17 23:50 | 49.264 | -0.1 | 22 | 16 | 16 | 3.283 | 3.286 | Dischg | Normal | Normal | Normal | 57.00% |
| 14 | 2017/7/18 0:20 | 49.27 | -0.104 | 23 | 16 | 17 | 3.283 | 3.286 | Dischg | Normal | Normal | Normal | 57.00% |
| 15 | 2017/7/18 0:50 | 49.266 | -0.104 | 24 | 17 | 18 | 3.283 | 3.286 | Dischg | Normal | Normal | Normal | 57.00% |
| 16 | 2017/7/18 1:20 | 49.274 | -0.108 | 24 | 18 | 18 | 3.284 | 3.286 | Dischg | Normal | Normal | Normal | 56.00% |
| 17 | 2017/7/18 1:50 | 49.283 | -0.108 | 25 | 18 | 19 | 3.284 | 3.287 | Dischg | Normal | Normal | Normal | 56.00% |
| 18 | 2017/7/18 2:20 | 49.285 | -0.108 | 25 | 19 | 20 | 3.284 | 3.288 | Dischg | Normal | Normal | Normal | 56.00% |
| 19 | 2017/7/18 2:50 | 49.285 | -0.108 | 26 | 20 | 20 | 3.284 | 3.288 | Dischg | Normal | Normal | Normal | 56.00% |
| 20 | 2017/7/18 3:20 | 49.287 | -0.108 | 26 | 20 | 21 | 3.284 | 3.288 | Dischg | Normal | Normal | Normal | 56.00% |

Connect to Battery View Window History Data Window Select cycle/event data Download and Save

06

Replacement



BEFORE YOU START

- Problem is located follow above trouble shooting steps.
- Switch off / cut off external power from inverter or DC side.
- Switch off the BMS follow the Power OFF process.
- Double-confirm **D+** and **D-** terminal are without power.

Replacement

1) Replace battery module:

- Charge existing module to full(100%SOC), make sure the new battery module is 100%SOC as well.
- Dismantle D+ and D- Power Cable, Communication Cable and Grounding Cable.
- Dismantle the BMS` s fix screw of left and right side. And dismantle the fix metal brackets.
- Remove the BMS, be careful there still has DC voltage on the front connector.
- Remove the battery module till the defective one, be careful there still has DC voltage on the front connector.
- Mount up the new battery module, connect back the BMS and fix the bracket and screws.
- Double check the installation, then connect back the power and communication cable.
- Restart the BMS, make a fully charge.

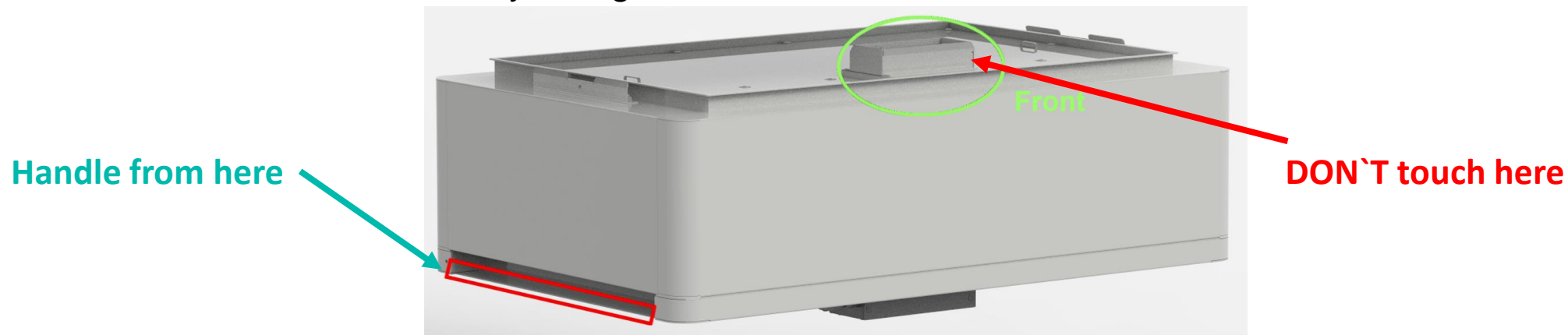

Replacement

2) Replace BMS:

- Dismantle D+ and D- Power Cable, Communication Cable and Grounding Cable.
- Dismantle the BMS` s fix screw of left and right side. And dismantle the fix metal brackets.
- Remove the BMS, be careful there still has DC voltage on the front connector.
- Mount up the new BMS, fix back the brackets and screws.
- Double check the installation, then connect back the power and communication cable.
- Restart the BMS, make a fully charge for SOC calibration.

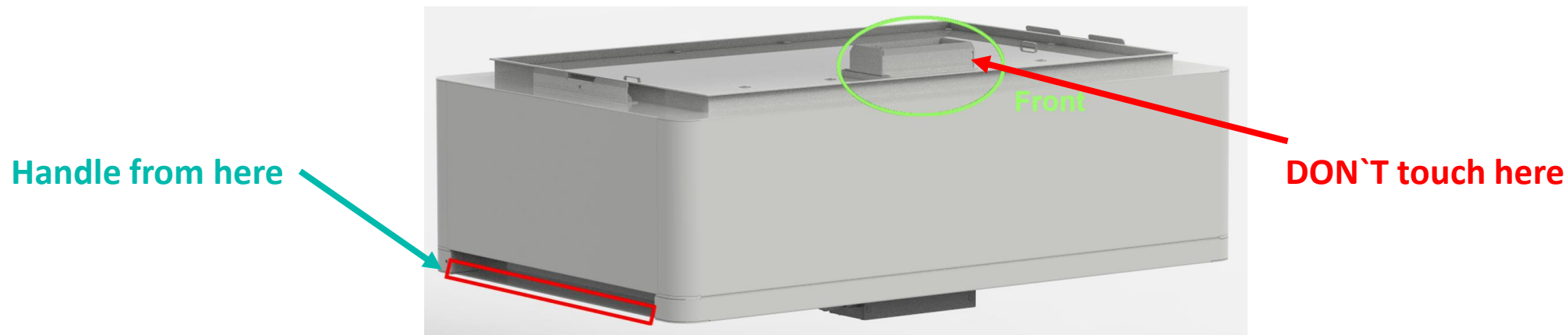

Thank You

For any questions, please contact: service@pylontech.com.cn